



Maintenance Manual

C5



Major Components

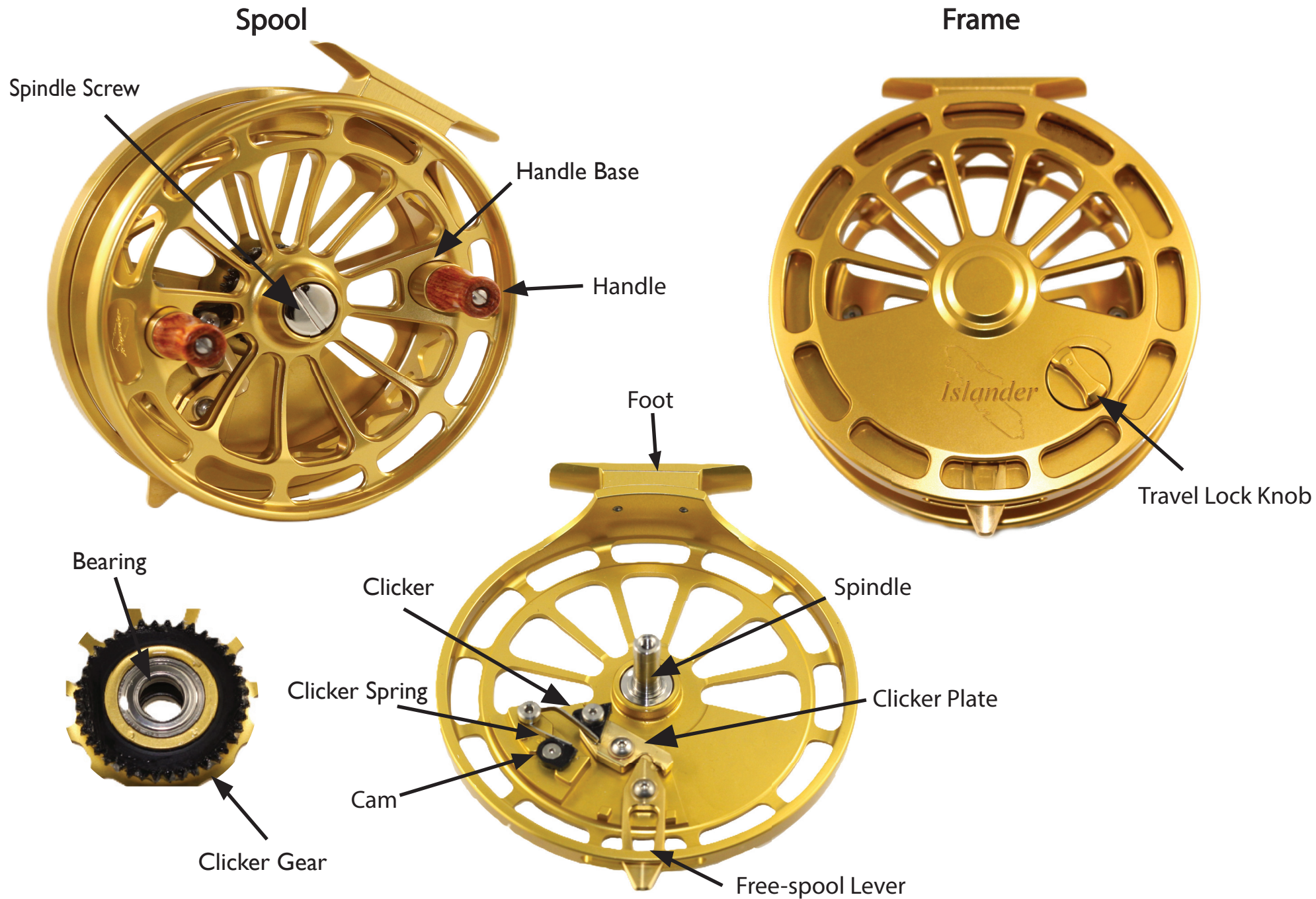

General Information

Thank you for purchasing the Islander C5 series float reel

In this manual, you will find information on how to take care of your new reel and troubleshoot any problems you may have with this reel.

By following these instructions, you will get a lifetime of enjoyment out of this product.

Features of the C5:

- Rotation – 2 low-friction high-quality stainless steel bearings.
- 5-inch diameter for faster retrieve and smoother drifts.
- Ergonomic brass free-spool lever to select between free spool mode and clicker mode.
- Travel Lock Setting – an adjustment knob on the frame switches between two tension settings, providing a stronger hold during transport to prevent accidental line spool out.
- Machined out of aerospace grade aluminum
- 2 Year Warranty– Our commitment to quality is backed by dedicated customer support and easy access to service, so you can fish with confidence knowing that your reel is built to last.
- Made in Canada – Proudly designed, machined, built, and tested on Vancouver Island, British Columbia.

Technical Support

Telephone - 1(250)-544-4856

Email - repairs@islander.com

How to Disassemble the Reel

To disassemble your reel:

1. Remove the spindle screw by turning it counterclockwise using a snug-fitting flathead screwdriver.
There is a captive rubber o-ring on the underside of the spindle screw that is important to the function of the reel.
Make sure it's present and properly seated before reassembly.
2. Grasp the outside of the frame with one hand and the outside of the spool with the other, and gently pull them apart in a straight line. Nothing should be forced during this step in disassembly or reassembly.
Do not twist and wobble the spool at this stage or damage to the bearings may occur.
3. At this point, there should be three assemblies.
The spindle screw, the spool, and the frame. All components should be visible and accessible for maintenance.

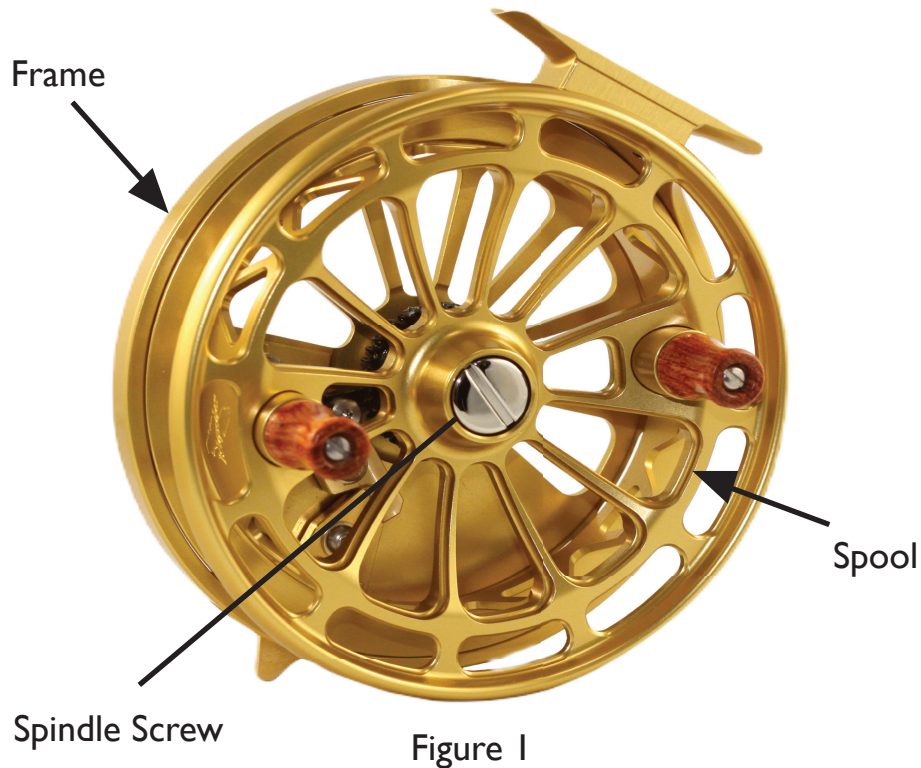

Figure 1



Figure 2 - Spindle Screw with O-ring

Reassembly Notes

- Disengage the clicker (Free-spool lever engaged).
- If the components feel misaligned or stuck, realign them carefully. These parts are designed to fit closely together but should not bind. If it still feels stuck, ensure the spindle is clean and check that the inner ring of the bearings is free of dirt.
- Tighten the spindle screw until it's secure, avoiding excessive force or overtightening.

Cleaning and Lubricating your Reel

Your reel comes pre-lubricated from the factory. To maintain optimal performance, replacing this lubrication should be done periodically, after submersion, or whenever the free spool lever feels gritty or sticky

Rinse the reel after every use in heavily sedimented waters to prevent buildup and potential damage to components.

The brass components will slowly patina over time.

A light-duty polishing compound with a soft cloth will take this layer off if you wish to remove it.

If the reel is submerged, dry thoroughly before storage.

Figure 3 - Travel Lock Knob

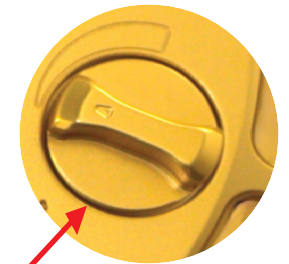

Grease

Oil

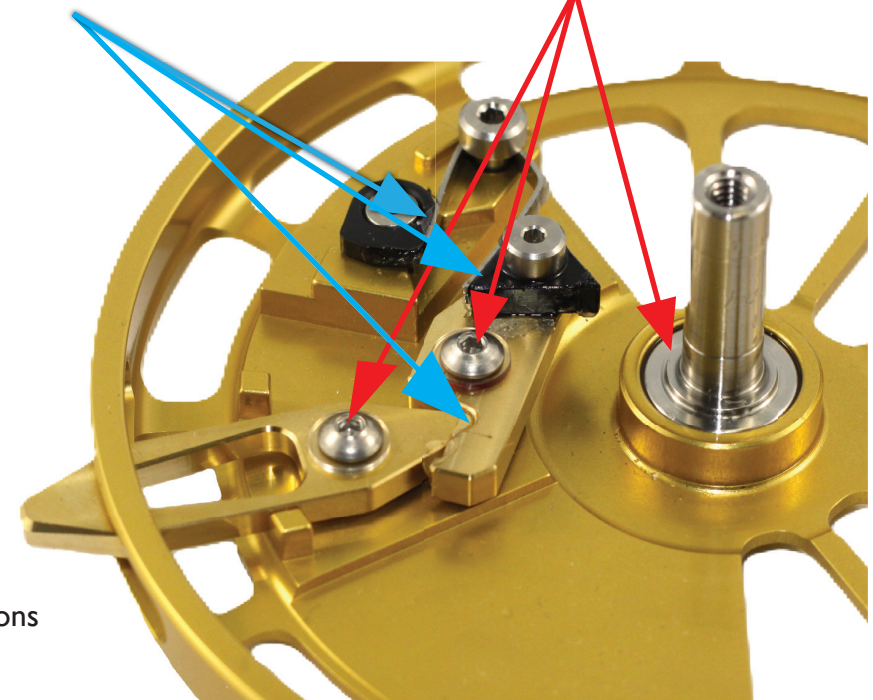

Figure 5 - Frame lubrication locations

Cleaning and Lubricating your Reel

Spool

1. Remove old grease from the clicker gear using a small brush or rag.
2. Ensure gear teeth are free of any sediment.
3. Wipe the bearings of any residue, being careful not to push any contaminants inside the bearings.
4. Clean the spokes of the spool with a cloth.
5. Apply a few drops of oil to the face of each bearing.
6. Apply an even amount of grease to the outside of the clicker gear teeth using a swab. Avoid getting grease into the bearings, or this will add friction to the reel.
7. Periodic lubrication of the handle assembly is recommended. Remove the screw holding the handle with a flat bladed screwdriver and clean thoroughly by wiping down the base with a soft cloth and running a cotton swab through the handle.
8. The o-ring under the spindle screw should be cleaned of any build-up and then oiled.

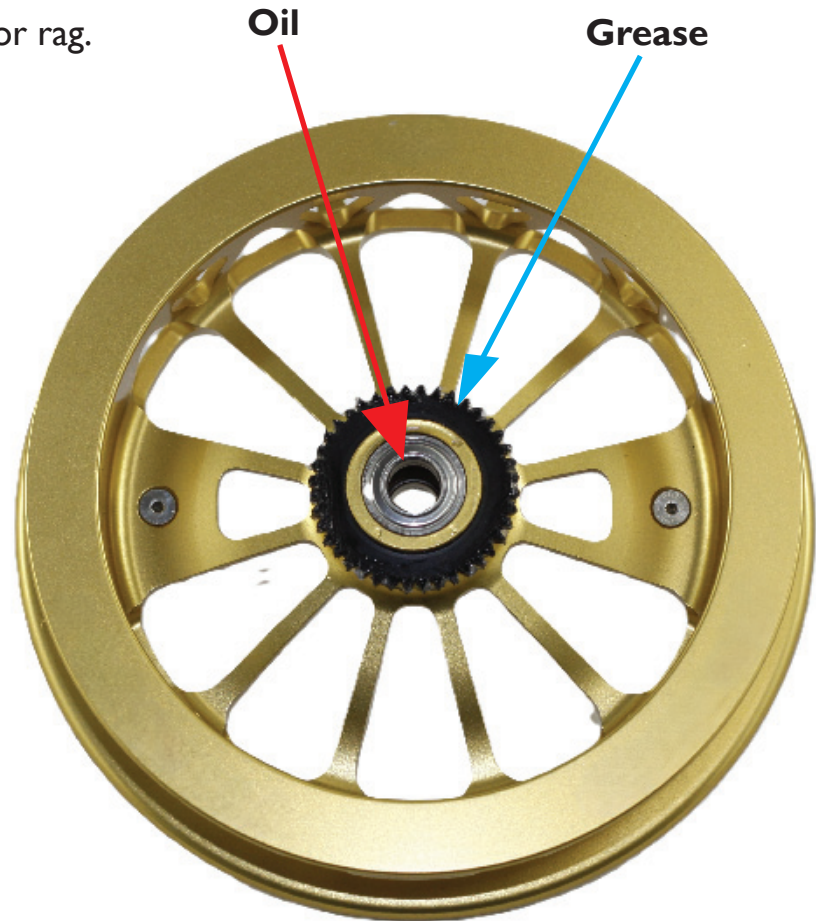

Figure 6 - Spool Lubrication Locations

Specifications

Diameter	Width	Weight	Capacity
5.0 in.	1.0 in.	11 oz.	350yds. 20# mono backing

Taking Care of Your Reel

When storing your reel between outings, avoid leaving it in free spool or with the travel lock engaged, as this can put unnecessary strain on the clicker spring.

Please note that the Travel Lock setting is intended for transport only and fishing on this setting will cause premature wear.



info@islander.com | www.islander.com

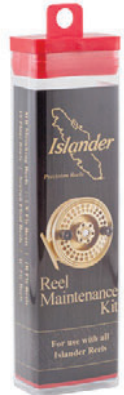

Reel Maintenance Kit

Use the same lubricant as the pros! A well lubricated and clean reel will last you a lifetime. We recommend Islander's Reel Maintenance Kit. It comes with all the lubricants you need for your C5 reel.

Oil: Super Lube® Multi-Purpose Synthetic-based Oil with PTFE®
Grease: Super Lube® Multi-Purpose Lubricant with Teflon®

Contact your local dealer or visit www.islander.com.

Copyright © 2017 Islander Precision Reels. All Rights Reserved.

Specifications and information contained in this manual are furnished for informational use only, and are subject to change at any time without notice.

Products and corporate names appearing in this manual may or may not be registered trademarks or copyrights of their respective companies, and are used only for identification or explanation and to the owners' benefit, without the intent to infringe.